

STONE

K2 STONE
930 MAUGHAN ROAD DUKE POINT
INDUSTRIAL PARK
NANAIMO, BC V9X 1J2
TOLL FREE: 1-866-722-2420
FAX: (250) 722-2406
www.k2stone.ca

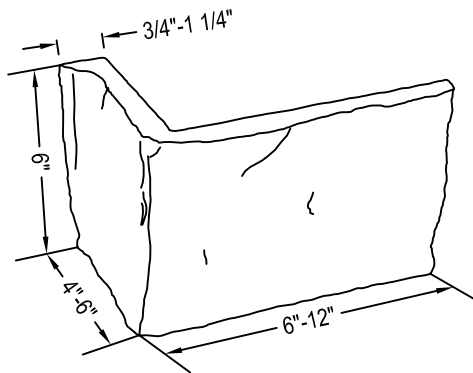

FLAT DETAIL



CORNER DETAIL

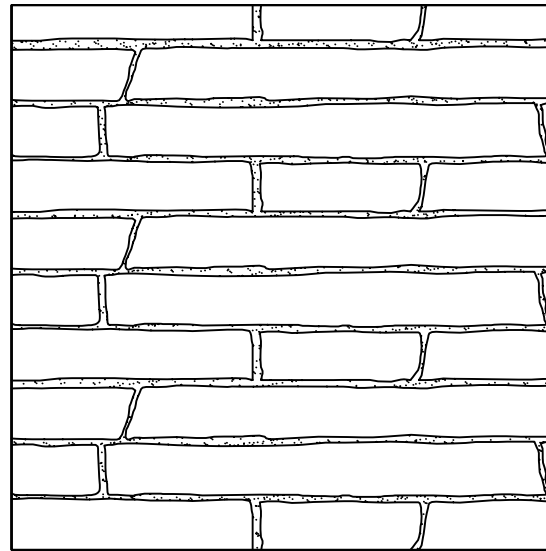

SIDE ELEVATION

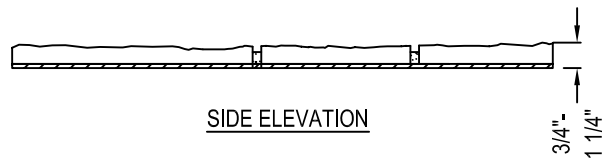

3/4" - 1-1/4" THICK
WEIGHT IS APPROXIMATELY 13 LBS/SF
ALL INDIVIDUAL NATURAL STONES
GOOD FOR INTERIOR AND EXTERIOR APPLICATION

NOTES:

1. ALSO AVAILABLE IN 2", 3", 4", 6" AND 8" TO ACHIEVE COURSED INSTALLATION
2. MORTAR JOINTS MAY VARY DEPENDING ON THE DESIRED INSTALLATION TYPE
3. INSTALLATION TO BE COMPLETED IN ACCORDANCE WITH MANUFACTURER'S SPECIFICATIONS AND LOCAL BUILDING CODES
4. FOR EXACT SPECIFICATION CONTACT MANUFACTURER.
5. DO NOT SCALE DRAWING.
6. THESE DRAWINGS ARE NOT FOR CONSTRUCTION PURPOSES AND ARE FOR INFORMATION PURPOSES ONLY. ALL INFORMATION CONTAINED HEREIN WAS CURRENT AT THE TIME OF DEVELOPMENT BUT MUST BE REVIEWED AND APPROVED BY THE PRODUCT MANUFACTURER TO BE CONSIDERED ACCURATE.
7. CONTRACTOR'S NOTE: FOR PRODUCT AND COMPANY INFORMATION VISIT WWW.CADDETAILS.COM/INFO REFERENCE NUMBER 4824-014.

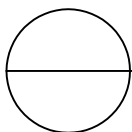

PACIFIC ASHLAR 6"

THINSTONE VENEER